

synthesis of this compound (I) on the basis of the following evidence: the integral ratio of aliphatic protons (at τ 6.67) to aromatic protons of I is 1:2, different from that reported previously. The only conceivable explanation for this difference is that the purity of samples used for various spectroscopic measurements differed, and apparently that for the nmr spectrum was impure.

In view of the similarity of the ultraviolet spectrum of I to that of phenanthrene, two structures, II and III, are proposed for this $C_{16}H_{12}$ compound.² The former compound is known³ and the latter unknown. Although

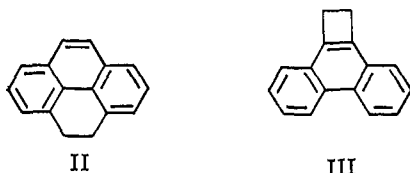

the melting point and ultraviolet spectrum of II are very similar of those of I, we prefer III as the more probable structure for I. The formation of III is at least mechanistically feasible, but no reasonable pathway to II seems conceivable. A definite structure assignment will be reported.⁴

(2) Professor E. H. White, in a recent private communication, has kindly suggested III as a possibility.

(3) C. S. Marvel and B. D. Wilson, *J. Org. Chem.*, **23**, 1483 (1958). Also see N. Jonathan, S. Gordon, and B. P. Dailey, *J. Chem. Phys.*, **36**, 2443 (1962).

Satoru Masamune, Masahiko Kato

Department of Chemistry, University of Alberta
Edmonton, Alberta, Canada

Received December 18, 1965

The Synthesis and Properties of Diphenylcyclopropenyldiazomethane, and a Structural Reassignment for the So-called Diphenyltetrahedrane

Sir:

Theorists seem to agree that planar cyclobutadiene (I) will be unstable with respect to distortions that yield filled electronic levels that are more stable,¹ and since a bending distortion could lead to tetrahedrane II, it was of interest to examine on independent synthesis of the latter type of compound.



We have prepared diphenylcyclopropenyldiazomethane (III) in the hope that thermally or on irradiation it would yield either an isolable tetrahedrane (IV)² or else, in view of the expected lability of this intermediate, dimeric products³ derived from 1,3-diphenylcyclobutadiene.

1,2-Diphenylcyclopropenyldiazomethane (III) was prepared in seven steps from 1,2-diphenylcyclopropenyl-3-carboxylic acid (see Table I for experimental details).⁴ All of the compounds cited in Table I

(1) W. N. Lipscomb, *Tetrahedron Letters*, No. 18, 20 (1959).

(2) A related cyclopropane synthesis is given by G. Stork and J. Ficini, *J. Am. Chem. Soc.*, **83**, 4678 (1961).

(3) E. H. White and H. C. Dunathan, *ibid.*, **86**, 453 (1964).

(4) R. Breslow, R. E. K. Winter, and M. Battiste, *J. Org. Chem.*, **24**, 415 (1959).

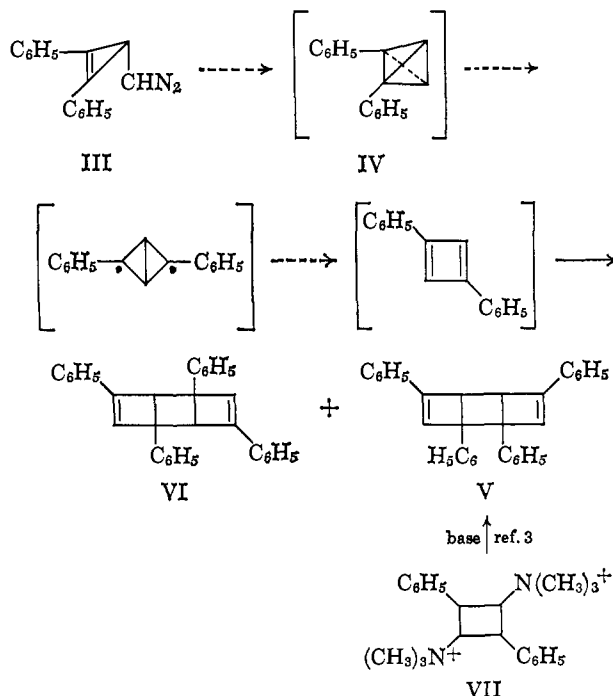

gave satisfactory elemental analyses and showed fine structure in the ultraviolet characteristic of the diphenylcyclopropenyl system.

Table I. Preparation of X

Compd	X	Reagents	Mp, °C
VIIIa	CO ₂ H		209 (lit ⁴ 209-211)
b	COCl	SOCl ₂ (25°)	100.7-101.2
c	CO ₂ NH ₂	NH ₃ (25°)	276
d	CN	Tosyl chloride + pyridine (0°)	117
e	CH ₂ NH ₂ ·HCl	LiAlH ₄ (-30°)	222-224 dec
f	CH ₂ NHCO ₂ CH ₃	CH ₃ OCOC (-15°)	107
g	CH ₂ N(NO)CO ₂ CH ₃	N ₂ O ₄ (-75°); NH ₃ to destroy excess	82-84
h	CH ₂ OH		68.3-69.6
i	CH ₂ OCOC ₆ H ₃ - (NO ₂) _{2-3,5}		154-154.5

The cyclopropenyldiazomethane was usually prepared at 0° by the reaction of compound VIIIg with solid sodium methylate still containing some methanol of solvation. The reaction was rapid and, judging from the intensity of the diazo peak in the infrared at 4.88 μ (2050 cm^{-1} in CCl₄), yields of about 80% were obtained. The diazo compound III proved to be abnormally sensitive to protic compounds (water, methanol, etc.) and therefore the diazo compound could not be separated from the other products of the reaction. Furthermore, the compound was also very sensitive to oxygen, and the syntheses were therefore carried out in evacuated systems. In dilute solution (oxygen-free) the compound had a half-life of about 30 min at 25°. In concentrated solutions the diazo group was lost rapidly, and for this reason the nmr spectrum could not be taken. The infrared spectra

Table II

9,10-Dimethylphenanthrene, λ_{\max} , $m\mu$ (log ϵ)		255 (4.75);	270 (4.47);	280 (4.28);	287 (4.05);	300 (4.11) ^a
Ratio of log ϵ		1.16	1.09	1.04	0.99	1.0
Cyclopentenophenanthrene (XII) ^e , λ_{\max} , $m\mu$ (log ϵ)	248 (4.71);	255 (4.81);	271 (4.30);	280 (4.12);	290 (4.04);	302 (4.13) ^b
Ratio of log ϵ	1.14	1.16	1.04	1.0	0.98	1.0
Masamune's compound (XI or IV?), λ_{\max} , $m\mu$ (log ϵ)	245 (4.57);	253 (4.66);	270 (4.10);	278 (3.96);	289 (3.88);	303 (4.01) ^c
Ratio of log ϵ	1.14	1.16	1.02	0.99	0.97	1.0

^a In ethanol. ^b Probably in ethanol. ^c In ethyl ether; values taken from the graph in ref 6. ^d E. J. Greenhow, D. McNeil, and E. N. White, *J. Chem. Soc.*, 986 (1952). ^e A. Butenandt, H. Dannenberg, and A. Rahman, *Chem. Ber.*, **88**, 1395 (1955).

were determined in a special cell with sapphire windows (transparent to *ca.* 7 μ). The ultraviolet spectrum was similar to that of the stable diphenylcyclopropenyl compounds, but the fine-structure characteristic of these compounds is washed out (VIIIh shows bands at 308, 317, and 333 $m\mu$); a broad band centered at 310 $m\mu$ was observed. The spectrum was determined in an ether-carbon tetrachloride mixture under vacuum in a special 10-cm cell. The structure of the diazo compound III was confirmed by the reaction of III with 3,5-dinitrobenzoic acid; the same ester was obtained from direct acylation of the carbinol VIIIh.

The thermal and photochemical decompositions of (1,2-diphenylcyclopropenyl)diazomethane yielded neither an isolable tetrahedrane nor the dimeric compounds V and VI. Instead, we were able to isolate 60–90% yields of nitrogen, 10–40% yields of diphenylacetylene, benzoic acid, the azine of VIII (X = CHO), polymeric substances, and in one run a $C_{16}H_{12}O_2$ compound, probably IX. The diphenylacetylene probably originates in the step in which nitrogen is lost from compound III, whereas the polymers may well come from the tetrahedrane IV; Wiberg and Ciula have reported that even bicyclobutanes polymerize readily.⁵ Attempts to trap reaction intermediate with cyclohexene or with butadiene (used as the solvent) were unsuccessful, as were attempts to isolate volatile compounds from reaction mixtures which had been hydrogenated immediately after the decomposition of the diazo compound.

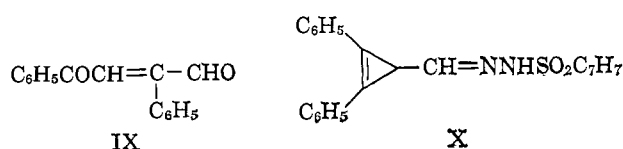

Recently, Masamune and Kato⁶ reported the synthesis of diphenyltetrahedrane (IV) from the irradiation of the tosylhydrazone of 1,2-diphenylcyclopropane-3-carboxaldehyde (X) in the presence of sodium methoxide. The authors considered four structures for the compound isolated and proposed that the tetrahedrane structure best accounted for their data. We wish to point out that a fifth structure, cyclobutenophenanthrene (XI), fits the data better than the four

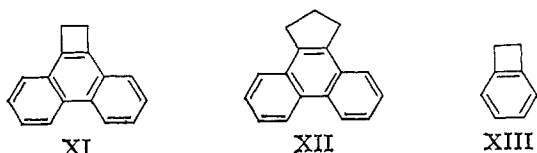

- (5) K. B. Wiberg and R. P. Ciula, *J. Am. Chem. Soc.*, **81**, 5261 (1959).
 (6) S. Masamune and M. Kato, *ibid.*, **87**, 4190 (1965).

considered. In particular, the ultraviolet spectrum reported by Masamune and Kato shows an intensity-wavelength relationship identical with the very characteristic pattern of the phenanthrenes (Table II). Since a 1,2-diphenylcyclopropane compound was reported to have only end absorption in the ultraviolet,⁷ it is difficult to account for the reported spectrum in terms of structure IV. Furthermore, the mass spectrum reported shows the parent peak approximately 5.8 times stronger than any other peak in the spectrum, with the exception of the $M - 1$ and $M - 2$ peaks which are also quite strong. This pattern would be expected for an aromatic compound such as XI which could not fragment readily, but not for diphenyltetrahedrane (IV). The nmr peaks listed by Masamune and Kato (τ 2.50 and 6.67) are satisfactory for the phenanthrene structure since the "benzo" analog XIII shows a peak for the benzylic hydrogens at τ 6.86.⁸ The 10:2 weighting of the aromatic to aliphatic hydrogens as reported⁶ is not consistent with structure XI, however, which demands an 8:4 ratio, and we assume that an error may have occurred in this measurement.

The pathway for the synthesis of cyclobutenophenanthrene in Masamune and Kato's work is worth comment. This compound might have arisen from the photochemical decomposition (in the presence of oxygen) of 1,2-diphenylcyclobutene⁹ (derivable from compound X) or, more intriguingly, from a compound at the 1,2-diphenylcyclobutadiene stage of oxidation.¹⁰

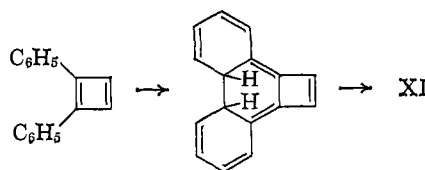

- (7) R. Breslow, J. Lockhart, and A. Small, *J. Am. Chem. Soc.*, **84**, 2793 (1962).

- (8) G. Fraenkel, Y. Asahi, M. J. Mitchell, and M. P. Cava, *Tetrahedron*, **20**, 1179 (1964).

- (9) E. H. White and J. P. Anhalt, *Tetrahedron Letters*, No. 44, 3937 (1965).

- (10) NOTE ADDED IN PROOF. A crystalline compound having the expected melting point and spectral data (mp 130–131°, hot stage): nmr τ 2.33 (m), 6.55 (s); ultraviolet (ether) 247 $m\mu$ (log ϵ 4.71), 254 (4.79), 270 (4.13), 277 (3.98), 287 (3.91), 302 (4.05), 323 (2.65), 339 (3.01), and 357 (3.12); and fluorescence nearly identical with XII (A. A. Lamola, G. S. Hammond, and F. B. Mallory, *Photochem. Photobiol.*, **4**, 259 (1965)) for cyclobutenophenanthrene (XI) has been synthesized by the irradiation of 9,10-dimethylene-9,10-dihydrophenanthrene (further details of synthesis and final proof of structure will be published in due course).

Emil H. White, Günther E. Maier
 Rolf Graeve, Ulrich Zirngibl, Earl W. Friend

Department of Chemistry, The Johns Hopkins University
 Baltimore, Maryland 21218

Received November 29, 1965